



SHREENATH ENGINEERING

PLOT NO-B/22, ZAVERI ESTATE,
NR. KATHWADA G.I.D.C., KATHWADA-SINGARVA ROAD,
KATHWADA, AHMEDABAD-382 430 , GUJARAT, INDIA.
MOBILE :- +91 9825530462, 9979082211
E-mail: neconvalves@yahoo.com / Website : www.neconvalves.com

DRN
MASUM

DATE
10/06/2024

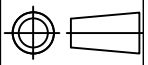

WAFER TYPE BUTTER FLY VALVE.

DRG. NO : SE/BFV/LO/80

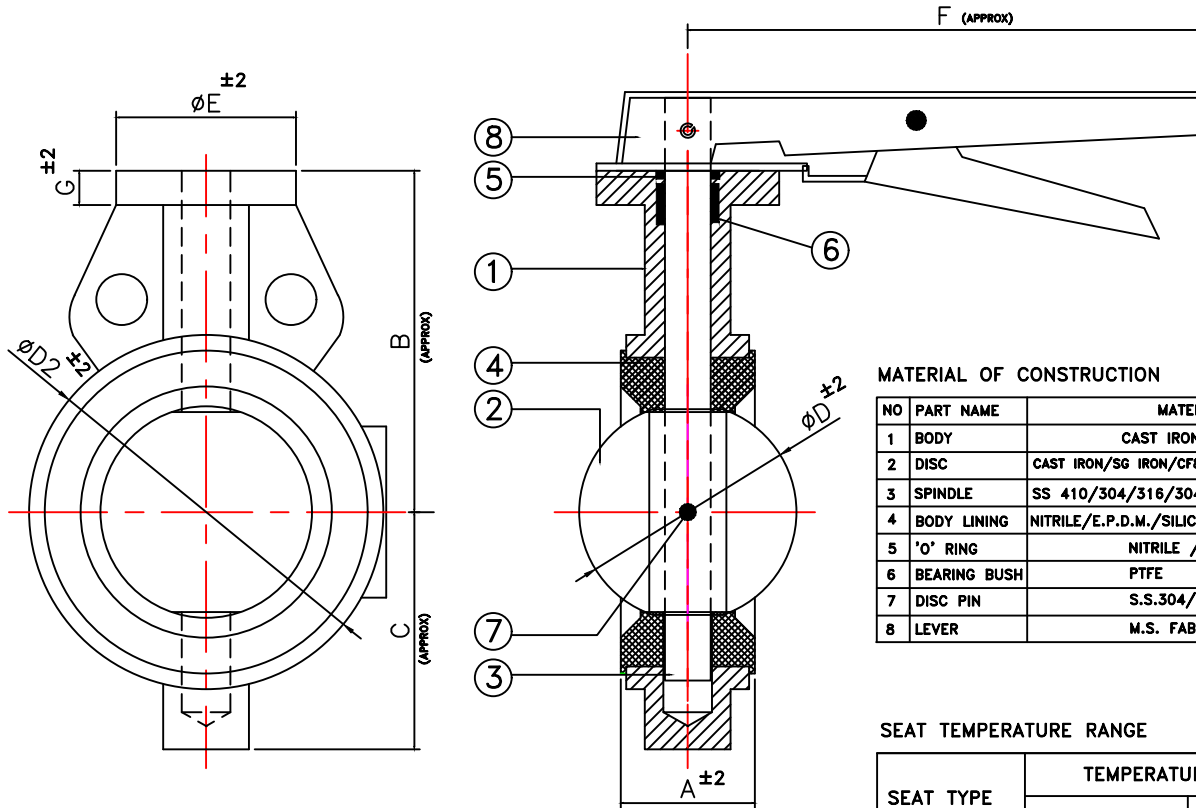

MATERIAL OF CONSTRUCTION

NO	PART NAME	MATERIAL
1	BODY	CAST IRON/SG IRON
2	DISC	CAST IRON/SG IRON/CF8/CF8M/CF3/CF3M
3	SPINDLE	SS 410/304/316/304L/316L
4	BODY LINING	NITRILE/E.P.D.M./SILICON/VITON/HYPALON
5	'O' RING	NITRILE / E.P.D.M.
6	BEARING BUSH	PTFE
7	DISC PIN	S.S.304/316
8	LEVER	M.S. FABRICATED

SEAT TEMPERATURE RANGE

SEAT TYPE	TEMPERATURE RANGE	
	Min.	Max.
NITRILE	-13°F(-25°C)	212°F(100°C)
EPDM	-13°F(-25°C)	250°F(120°C)
SILICON	-58°F(-50°C)	356°F(180°C)
VITON	-23°F(-5°C)	392°F(200°C)
HYPALON	-4°F(-20°C)	250°F(120°C)

TESTING

PRESSURE RATING	HYDROSTATIC SHELL TEST		HYDROSTATIC SEAT TEST	
	Kg/CM2	PSI	Kg/CM2	PSI
PN16	22	310	16	225
PN10	15	210	10	140

NOTE : ALL DIMENSION ARE IN MM.

SIZE		A	B	C	D	D2	E	F	G	TOP FLANGE MOUNTING (I.S.O 5211)	PCD	HOLE DIA	NOS HOLE	APPROX WEIGHT (KGs)
MM	INCH													
80	3"	46	118	85	67	125	65	215	15	F05	50	7	4	3.6

CONFORMITY TO CODES & STANDARDS

- 1) GENERAL DESIGN & MANUFACTURE :- BS 5155 / API 609 / EN 593 / IS 13095
- 2) VALVE FACE TO FACE DIMENSION :- BS 5155 / ISO 5752 / API 609
- 3) TOP FLANGE DRILLING :- ISO 5211
- 4) VALVE INSPECTION & TESTING :- BS 6755 Part - I / API 598 / EN 12266-1
- 5) FLANGE STANDARD CONFORMITY :- ANSI 150 / ANSI 125 / BS 10 TAB D & E
IS 6392 NP 0.6 / 1.0 / 1.6

THIS DRAWING IS PROPERTY OF SHREENATH ENGINEERING.
SHREENATH ENGINEERING RESERVES RIGHTS OF USE, CHANGE & MODIFY PRODUCT DESIGN OR PRODUCT WITHOUT PRIOR NOTICE.

CHECKED BY :-

APPROVED :-